

# HYLIFT® UNDERSINK PUMPS

## HYLIFT® 70



### FEATURES

Compact and easy to install, the All Purpose Pumps HYLIFT® 70 units come fully assembled and plug directly into a standard electrical outlet. The heavy duty pump easily handles domestic and commercial waste and has been selected for its high performance & extremely quiet operation.

- > WaterMark Certified complying the WMTS 106:2019. Certification N°: 23399.
- > Durable 70 litre stainless steel tank
- > 240v submersible pump options for handling of large solids and fibres, high heads, long distances and corrosion resistance
- > Compact design, supplied fully assembled with all connection points on one face
- > Single trade installation, complete with 2 metre power cable and standard 3 pin, 240v 10 amp plug
- > Odour filter and anti flood valve accessory\* (included)
- > Audible / Visual high level warning alarm, 4 Mountable Positions voltage free common alarm output for BMS connection
- > 50mm FBSP Inlet
- > 32mm FBSP Discharge



30 YEARS INDUSTRY EXPERIENCE

### RANGE

MODEL	PRODUCT CODE	PUMP	MAX. SOLIDS HANDLING	MAX. HEAD	VOLTAGE/KW	ADDITIONAL FEATURE
HYLIFT-70	8650026	HV32.04.1A.2	20mm	9.2m	240V / 0.4kW	-
HYLIFT-70HVS075	8650031	HVS50.075.1A.2	35mm	13m	240V / 0.75kW	316 S/S Pump, Chamber & Valves
HYLIFT-70HV075	8650030	HV50.075.1A.2	35mm	13m	240V / 0.75kW	Higher Head & Larger Solids Handling
HYLIFT-70HD075	8650028	HD50.075.1A.2	10mm	15.5m	240V / 0.75kW	Higher Head

### PERFORMANCE

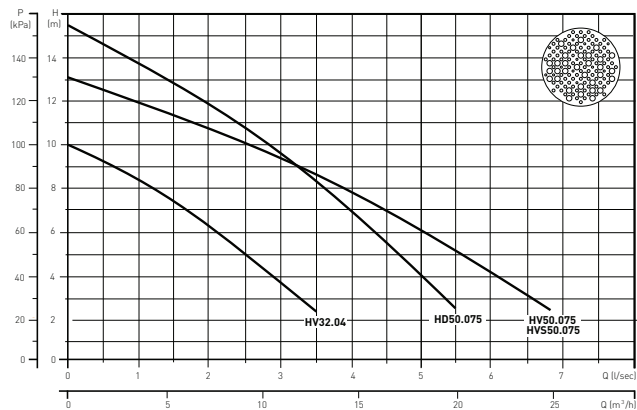

### DIMENSIONS

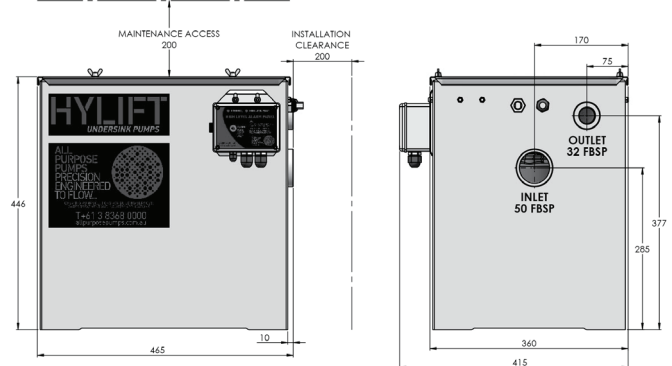

### NOTES

1. Dimensions in mm and are approximate
2. Allow minimum of 200mm above unit for maintenance
3. High level alarm needs weather protection if mounted outside

### HYLIFT APPLICATION GUIDELINE

Based on typical offline amenities application

HYLIFT 40	HYLIFT 70
<ul style="list-style-type: none"> <li>&gt; Tight spaces and less demanding applications</li> <li>&gt; Suitable for 1-30 people with one dishwasher.</li> </ul>	<ul style="list-style-type: none"> <li>&gt; High-use applications including restaurants, large office spaces, greasy and fatty wastes.</li> <li>&gt; Suitable for 1-80 people with two dishwashers.</li> </ul>

### FLOOD PROTECTION & SAFETY DEVICES

- > Audible / Visual High level alarm with flexible positioning (Optional)
- > Flood Prevention Safety interlock kits (Optional - Requires High Level Alarm)
- > Unique combined Odour Filter and anti flood valve.

APP ADVICE	FEATURE	BENEFIT
	Powerful & reliable pump	<ul style="list-style-type: none"> <li>&gt; No need to run pump line on grade</li> <li>&gt; Handles solids and fibres</li> <li>&gt; Multiple bends, rises and falls in the pump line is no problem</li> </ul>
	Odour filter & anti flood valve accessory (included)	<ul style="list-style-type: none"> <li>&gt; Eliminates the need for vent pipework</li> </ul>

### \*NOTE

1. Chemical, thinners and acidic based products will reduce the Filter service life

